

CARTA DE APROXIMAÇÃO
POR INSTRUMENTOS (IAC)
INSTRUMENT APPROACH CHART (IAC)

BRASÍLIA / PRES. JUSCELINO KUBITSCHKE, INTL (SBBR)
ILS z Rwy 29R

AD ELEV: 3497'	ATIS 127.80	APP BRASÍLIA 119.20 119.50 119.70 120.00 129.60	TWR BRASÍLIA 118.10 118.45 121.50	GNDC BRASÍLIA 121.80
-----------------------	------------------------	--	--	---------------------------------

1) OBSERVAR COMPULSORIAMENTE SEÇÃO CAR DA AIP-MAP.
1) CAR SECTION OF AIP-MAP SHALL BE OBSERVED.

APROXIMAÇÃO PERDIDA: SUBIR PARA 5000' (VA) NO RUMO 287 ENTÃO CURVAR A DIREITA (DF) E SUBIR PARA 6000' PARA ESPERA NO WAYPOINT BR056.
MISSED APPROACH: CLIMB TO 5000' (VA) ON TRACK 287 THEN TURN RIGHT (DF) AND CLIMB TO 6000' FOR HOLD AT BR056.

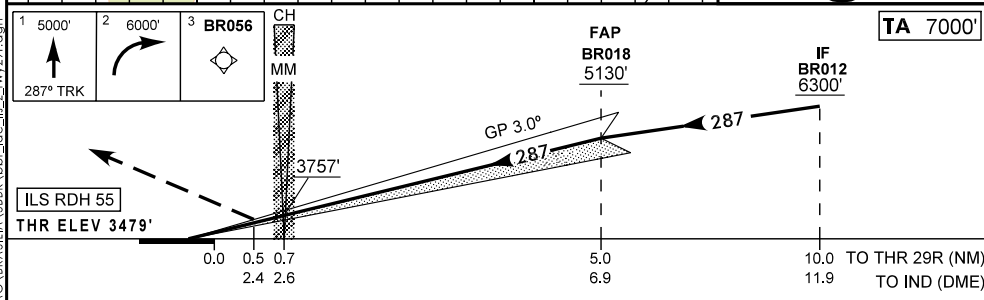
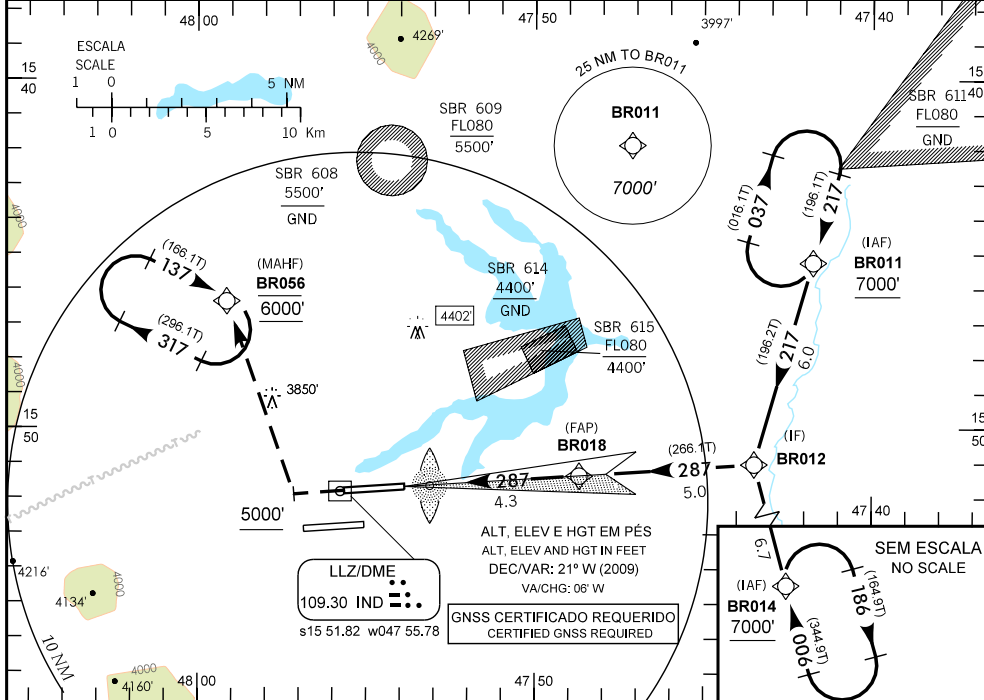

DME IND	2.4	2.9	3.9	4.9	5.9	BR018	KT	090	110	130	150	170	190
ALT	3679	3852	4172	4490	4809	5130	FPM	450	550	650	750	850	950
(HGT)	200	373	693	1011	1329	1647	FAF-MAPT 5 NM	NIL					

POUSO DIRETO STRAIGHT-IN	CAT	A	B	C	D	E
	DA / OCH / TETO	3679 / 200 / 200				
CAT I	ALS / NO ALS / RVR ALS (m)	800 / 1200 / 800				
	MDA / OCH / TETO	NA				
CIRCULAR TO CIRCLE	MDA / OCH / TETO	NA				
	VIS (m)	NA				

08 MAR 12 AIRAC MODIFICAÇÕES / CHANGES: IDENT, PROC.

SBBR

ILS z Rwy 29R

\\lce_server-05\ostig-prod\lce\AIP-MAP\MVA\FICAO\BRASILIA\SBBR\br-jac-ils_z_rwy29r.dgn

DEPARTAMENTO DE CONTROLE DO ESPAÇO AÉREO - COMAER - BRASIL